



1 CEA-CA Series

*Stainless steel threaded centrifugal pumps.
Wide range of pumps for domestic and industrial applications.*

*Single-impeller (CEA) and dual-impeller (CA) models available.
"V" versions with elastomers in FPM for temperatures up to 110°C and "N" versions made entirely from AISI 316 stainless steel available on request.*

SPECIFICATIONS

Delivery: up to 31 m³/h

Head: up to 62 m

Power supply: three-phase and single-phase 50 and 60 Hz

Power: 0.37 kW to 3 kW

Maximum operating pressure: 8 bar

Temperature of pumped liquid:

-10°C to +85°C (CEA-CA)

-10°C to +110°C (CEA-V CA-V with elastomers in FPM)

Insulation class: F

Protection: IP55

MATERIALS

Pump body: Stainless steel

Impeller: Stainless steel

Diffuser: Stainless steel

Seal housing: Stainless steel

Adapter: Aluminium

Mechanical seal:

Ceramic/Carbon/NBR

Fill and drain plugs:

Stainless steel

Elastomers: NBR

APPLICATIONS

- Water distribution
- Rain water collection
- Industrial washing equipment
- Pressure boosting
- General industry
- Irrigation
- Water treatment
- Cooling and chilling
- Swimming pools ("N" versions)
- Heat recovery
- Heating, ventilation and air-conditioning



For a complete list of technical information, consult www.lowara.com

Engineered for life



General Catalogue

CEA-CEA(N) SERIES HYDRAULIC PERFORMANCE TABLE ~2850 rpm 50 Hz

1

PUMP TYPE	RATED POWER		Q = DELIVERY																		
			l/min	30	40	60	80	100	120	140	160	180	200	250	300	350	400	430	480	520	
	0	0	0	0	0	0	0	0	0	0	0	0	0	0	0	0	0	0	0	0	
	kW	HP	m ³ /h	1,8	2,4	3,6	4,8	6	7,2	8,4	9,6	10,8	12	15	18	21	24	26	29	31	
H = TOTAL HEAD METRES COLUMN OF WATER																					
CEA(M) 70/3	0,37	0,5	22	20,1	19,1	16,6	12,8														
CEA(M) 70/5	0,55	0,75	31,1	28,8	27,7	24,7	20,2														
CEA(M) 80/5	0,75	1	32	30	29,3	27,4	24,7	21													
CEA(M) 120/3	0,55	0,75	22,4			18,9	17,5	15,9	14	11,8	9,2										
CEA(M) 120/5	0,9	1,2	31,8			28,2	26,5	24,6	22,4	20	17,3										
CEA(M) 210/2	0,75	1	17,7						16,5	16,1	15,6	15	14,4	12,6	10,4						
CEA(M) 210/3	1,1	1,5	20,8						19,7	19,3	19	18,5	18	16,5	14,4						
CEA(M) 210/4	1,5	2	25,5						24,8	24,5	24	23,6	23	21,3	19						
CEA(M) 210/5	1,85	2,5	29						28,2	27,9	27,5	27,1	26,6	25,1	23,1						
CEA(M) 370/1	1,1	1,5	16,3									15,5	15,2	14,3	13	11,4	9,4	8,1			
CEA(M) 370/2	1,5	2	20,4										19,1	18,3	17,2	15,8	14,1	13	10,8		
CEA(M) 370/3	1,85	2,5	24,4										22,9	22,1	21,1	19,8	18,2	17,1	15	13	
CEA370/5	3	4	30,3										28,3	27,5	26,5	25,3	23,8	22,8	21	19,0	

cea-2p50-en_d_th

ELECTRICAL DATA

PUMP TYPE SINGLE-PHASE	INPUT POWER*	INPUT CURRENT*	CAPACITOR
	kW	220-240 V A	μF / 450 V
CEAM 70/3	0,6	2,72	14
CEAM 70/5	0,97	4,55	16
CEAM 80/5	1,07	4,87	20
CEAM 120/3	0,91	4,33	16
CEAM 120/5	1,39	6,24	25
CEAM 210/2	1,13	5,1	20
CEAM 210/3	1,48	6,68	30
CEAM 210/4	1,91	8,6	40
CEAM 210/5**	2,72	12,7	70
CEAM 370/1	1,49	6,75	30
CEAM 370/2	2,05	9,26	40
CEAM 370/3**	2,72	12,7	70

PUMP TYPE THREE-PHASE	INPUT POWER*	INPUT CURRENT*	INPUT CURRENT*
	kW	220-240 V A	380-415 V A
CEA 70/3	0,61	2,51	1,45
CEA 70/5	0,88	2,86	1,65
CEA 80/5	1,06	3,65	2,11
CEA 120/3	0,82	2,74	1,58
CEA 120/5	1,32	4,52	2,61
CEA 210/2	1,12	3,76	2,17
CEA 210/3	1,43	4,68	2,7
CEA 210/4	1,84	6,04	3,49
CEA 210/5	2,28	8,35	4,82
CEA 370/1	1,44	4,71	2,72
CEA 370/2	1,99	6,32	3,65
CEA 370/3	2,47	8,63	4,98
CEA 370/5**	3,58	11,0	6,38

*Maximum value in specified range.

** Electric pumps equipped with PLM motors.

cea-2p50-en_c_te



CA-CA(N) SERIES

HYDRAULIC PERFORMANCE TABLE ~2850 rpm 50 Hz

PUMP TYPE	RATED POWER		Q = DELIVERY												
			l/min	0	30	40	50	60	70	80	100	120	150	180	210
			m ³ /h	0	1,8	2,4	3	3,6	4,2	4,8	6	7,2	9	10,8	12,6
			H = TOTAL HEAD METRES COLUMN OF WATER												
	kW	HP													
CA(M) 70/33	0,75	1	42,9	38,8	36,9	34,6	31,7	28,2	23,9						
CA(M) 70/34	0,9	1,2	48,8	45,1	43,2	40,7	37,7	34,0	29,5						
CA(M) 70/45	1,1	1,5	56,2	52,0	49,8	47,1	43,9	39,9	35,3						
CA(M) 120/33	1,1	1,5	44,3			39,1	37,8	36,4	34,8	31,4	27,6	21,0			
CA(M) 120/35	1,5	2	54,0			49,4	48,1	46,6	44,9	41,2	36,8	29,3			
CA(M) 120/55	2,2	3	63,8			59,6	58,2	56,6	54,8	50,6	45,7	37,1			
CA(M) 200/33	1,85	2,5	43,2			41,8	41,2	40,6	39,9	38,3	36,4	33,2	29,5	25,5	
CA 200/35	2,2	3	53,5			52,4	51,9	51,4	50,7	49,2	47,5	44,3	40,6	36,5	
CA 200/55	3	4	62,6			61,0	60,6	60,1	59,5	58,2	56,6	53,8	50,4	46,2	

ca-2p50-en_c_th

ELECTRICAL DATA

PUMP TYPE	INPUT POWER*	INPUT CURRENT*	CAPACITOR
SINGLE-PHASE	kW	220-240 V A	μF / 450 V
CAM 70/33	1,15	5,16	20
CAM 70/34	1,39	6,22	25
CAM 70/45	1,76	7,92	30
CAM 120/33	1,67	7,53	30
CAM 120/35	2,18	9,87	40
CAM 120/55**	2,72	12,7	70
CAM 200/33**	2,72	12,7	70
-	-	-	-
-	-	-	-

PUMP TYPE	INPUT POWER*	INPUT CURRENT*	INPUT CURRENT*
THREE-PHASE	kW	220-240 V A	380-415 V A
CA 70/33	1,14	3,78	2,18
CA 70/34	1,32	4,52	2,61
CA 70/45	1,71	5,23	3,02
CA 120/33	1,62	5,06	2,92
CA 120/35	2,13	6,58	3,8
CA 120/55	2,62	8,89	5,13
CA 200/33	2,34	8,44	4,87
CA 200/35**	2,63	8,2	4,74
CA 200/55**	3,58	11	6,38

*Maximum values within operating range.

** Electric pumps equipped with PLM motors.

ca-2p50-en_b_te



General Catalogue

CEA SERIES OPERATING CHARACTERISTICS AT 50 Hz

1

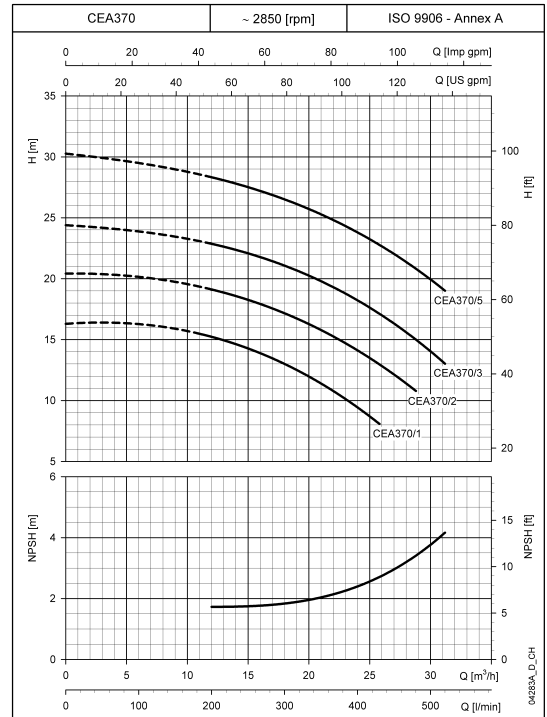
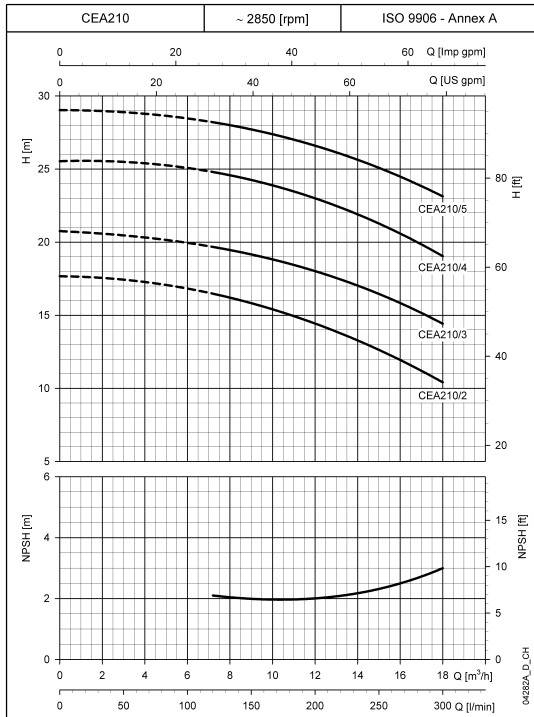
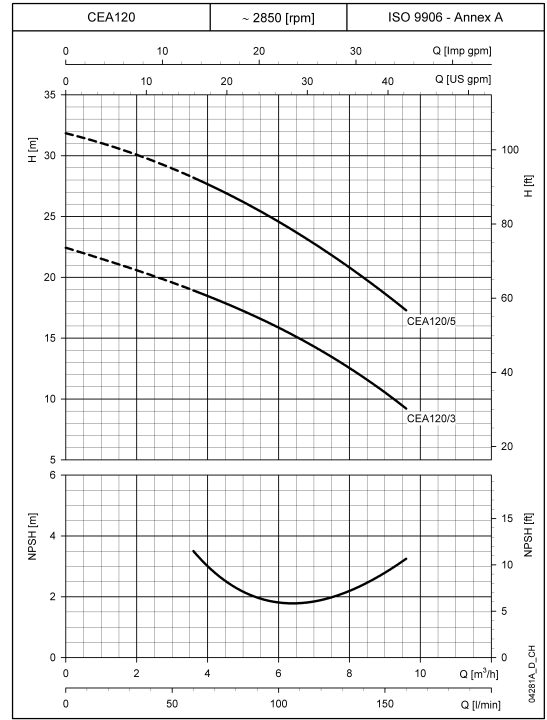
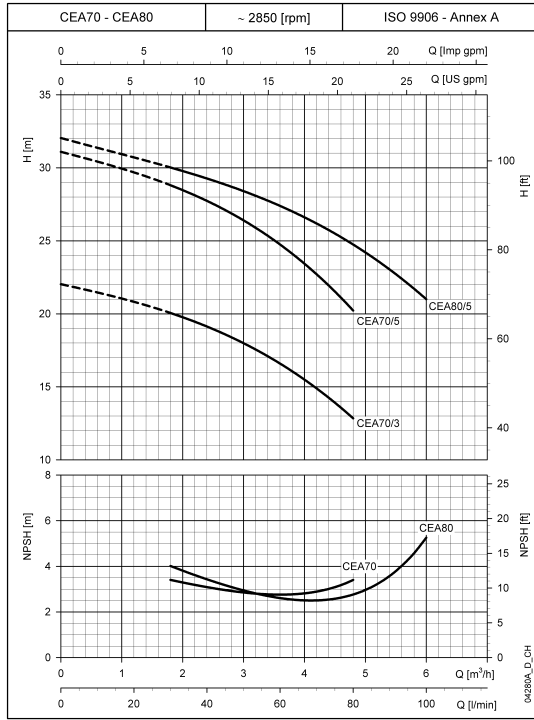

These performances are valid for liquids with density $\rho = 1.0 \text{ kg/dm}^3$ and kinematic viscosity $\nu = 1 \text{ mm}^2/\text{s}$.

Engineered for life



CA SERIES

OPERATING CHARACTERISTICS AT 50 Hz

1

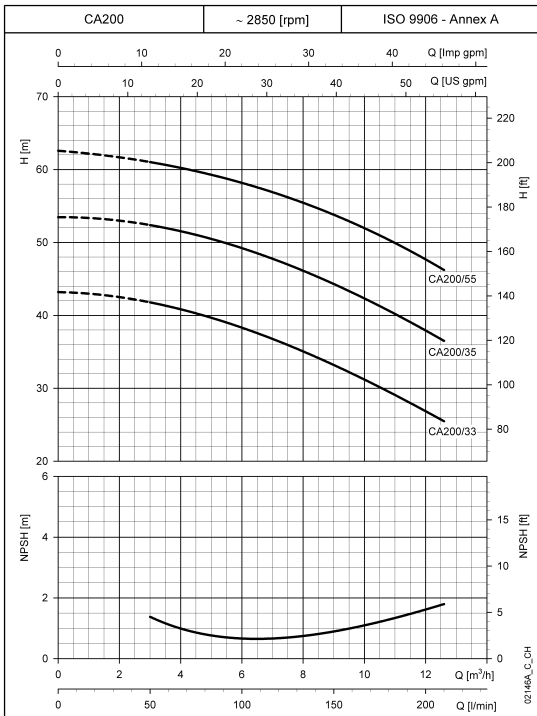
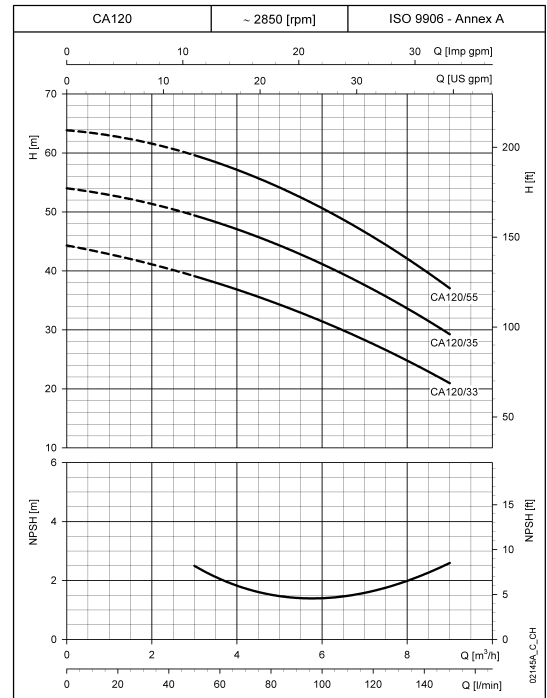
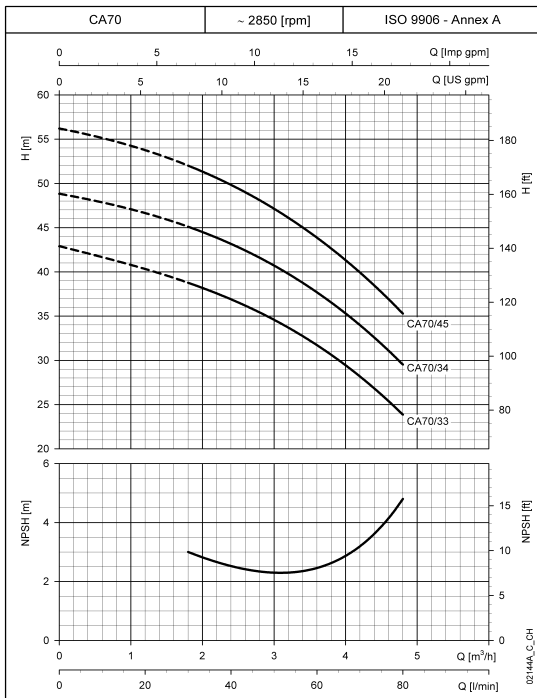

These performances are valid for liquids with density $\rho = 1.0 \text{ kg/dm}^3$ and kinematic viscosity $\nu = 1 \text{ mm}^2/\text{s}$.

Engineered for life



General Catalogue

CEA-CEA(N) SERIES - DIMENSIONS AND WEIGHTS

1

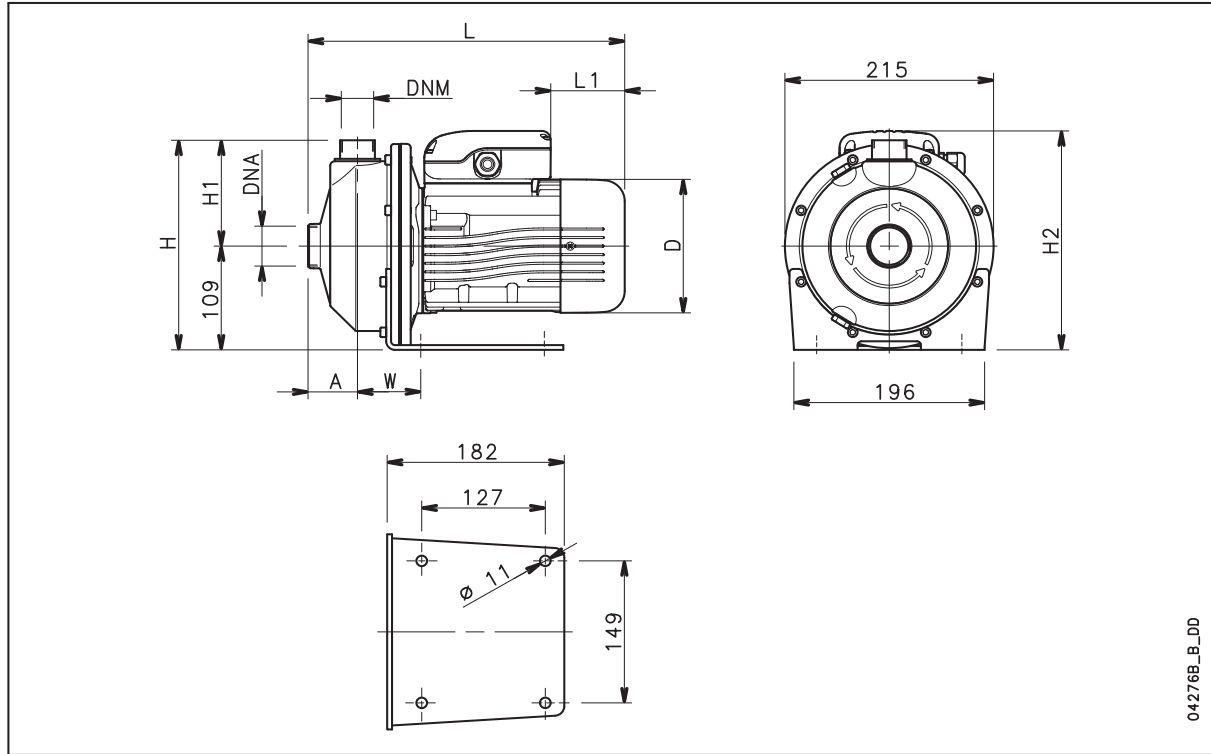

04276B_B_DD

PUMP TYPE	DIMENSIONS (mm)								DNA	DNM	WEIGHT kg
	A	D	H	H1	H2	L	L1	W			
CEAM 70/3	51	120	220	111	220	311	62	65	Rp 1¼	Rp 1	9,7
CEAM 70/5	51	140	220	111	230	325	76	65	Rp 1¼	Rp 1	11,6
CEAM 80/5	51	140	220	111	230	325	76	65	Rp 1¼	Rp 1	12,5
CEAM 120/3	51	140	220	111	230	325	76	65	Rp 1¼	Rp 1	11,5
CEAM 120/5	51	140	220	111	239	325	31	65	Rp 1¼	Rp 1	13
CEAM 210/2	54	140	222	113	230	339	76	76	Rp 1½	Rp 1¼	13
CEAM 210/3	54	156	222	113	246	385	69	76	Rp 1½	Rp 1¼	14,5
CEAM 210/4	54	156	222	113	246	385	69	76	Rp 1½	Rp 1¼	16,1
CEAM 210/5*	54	174	222	113	243	429	84	76	Rp 1½	Rp 1¼	17
CEAM 370/1	54	156	222	113	246	385	69	76	Rp 2	Rp 1¼	14
CEAM 370/2	54	156	222	113	246	385	69	76	Rp 2	Rp 1¼	16,1
CEAM 370/3*	54	174	222	113	243	429	84	76	Rp 2	Rp 1¼	20
CEA 70/3	51	120	220	111	220	311	62	65	Rp 1¼	Rp 1	9,7
CEA 70/5	51	140	220	111	230	325	76	65	Rp 1¼	Rp 1	11,6
CEA 80/5	51	140	220	111	230	325	76	65	Rp 1¼	Rp 1	12,5
CEA 120/3	51	140	220	111	230	325	76	65	Rp 1¼	Rp 1	11,5
CEA 120/5	51	140	220	111	230	325	76	65	Rp 1¼	Rp 1	13
CEA 210/2	54	140	222	113	230	339	76	76	Rp 1½	Rp 1¼	13
CEA 210/3	54	156	222	113	238	385	114	76	Rp 1½	Rp 1¼	14,5
CEA 210/4	54	156	222	113	238	385	114	76	Rp 1½	Rp 1¼	16,1
CEA 210/5	54	156	222	113	238	385	114	76	Rp 1½	Rp 1¼	14,4
CEA 370/1	54	156	222	113	238	285	114	76	Rp 2	Rp 1¼	14
CEA 370/2	54	156	222	113	238	385	114	76	Rp 2	Rp 1¼	16,1
CEA 370/3	54	156	222	113	238	385	114	76	Rp 2	Rp 1¼	17,7
CEA 370/5*	54	174	222	113	243	429	172	76	Rp 2	Rp 1¼	21

* Electric pumps equipped with PLM motors.



CA-CA(N) SERIES - DIMENSIONS AND WEIGHTS

1

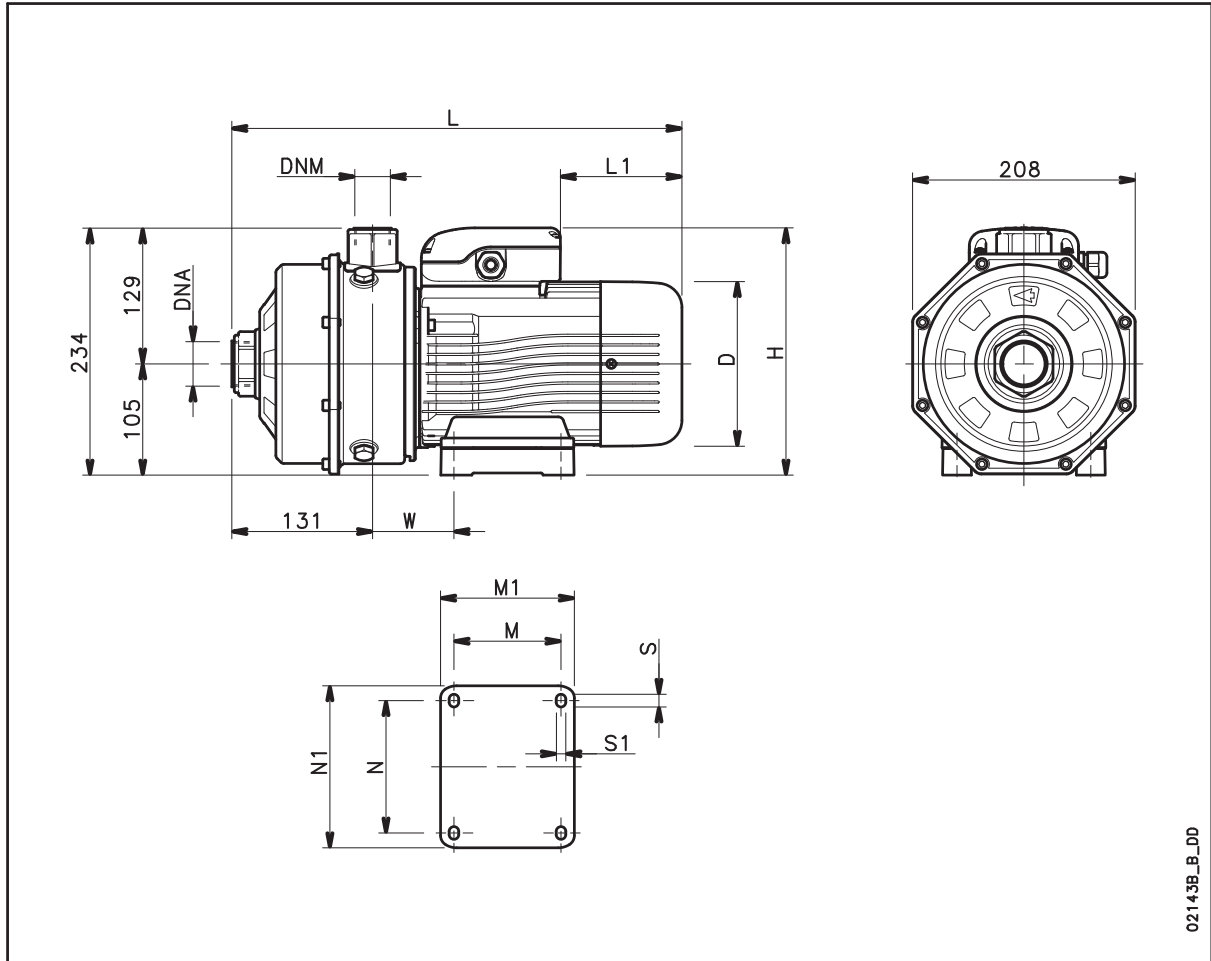

PUMP TYPE	DIMENSIONS (mm)											DNA	DNM	WEIGHT
	D	H	L	L1	M	M1	N	N1	S	S1	W			
CAM 70/33	140	226	383	76	90	113	112	135	12	7	66	Rp 1¼	Rp 1	15
CAM 70/34	140	235	383	31	90	113	112	135	12	7	66	Rp 1¼	Rp 1	15,8
CAM 70/45	156	242	420	69	100	125	125	153	12	9	76	Rp 1¼	Rp 1	18,5
CAM 120/33	156	242	420	69	100	125	125	153	12	9	76	Rp 1¼	Rp 1	18,4
CAM 120/35	156	242	420	69	100	125	125	153	12	9	76	Rp 1¼	Rp 1	20,2
CAM 120/55*	174	239	454	84	125	155	140	170	13	10	98	Rp 1¼	Rp 1	27
CAM 200/33*	174	239	454	84	125	155	140	170	13	10	98	Rp 1½	Rp 1	27
CA 70/33	140	226	383	76	90	113	112	135	12	7	66	Rp 1¼	Rp 1	14,9
CA 70/34	140	226	383	76	90	113	112	135	12	7	66	Rp 1¼	Rp 1	15,7
CA 70/45	156	234	420	114	100	125	125	153	12	9	76	Rp 1¼	Rp 1	17
CA 120/33	156	234	420	114	100	125	125	153	12	9	76	Rp 1¼	Rp 1	16,8
CA120/35	156	234	420	114	100	125	125	153	12	9	76	Rp 1¼	Rp 1	18,7
CA 120/55	156	234	420	114	100	125	125	153	12	9	76	Rp 1¼	Rp 1	20,3
CA 200/33	156	234	420	114	100	125	125	153	12	9	76	Rp 1½	Rp 1	20
CA 200/35*	174	239	454	172	125	155	140	170	13	10	98	Rp 1½	Rp 1	25
CA 200/55*	174	239	454	172	125	155	140	170	13	10	98	Rp 1½	Rp 1	27

* Electric pumps equipped with PLM motors.

ca-2p50-en_d_ld