



TKS Series

Single-phase pump with integrated Teknospeed variable speed device.

Connected to electric pumps BG, CA, CEA, HM and SV.

SPECIFICATIONS

Delivery: up to 10 m³/h

Head: up to 75 metres

Power supply: single-phase
50 and 60 Hz

Power: 0.37 kW to 1.1 kW

Motor starting: variable frequency
operation

Maximum operating pressure:
8 bar (BG, CA, CEA and HM series),
16 bar (SV series)

Temperature of pumped liquid:
0°C to +40°C

Number of pumps: 1

Pump type: horizontal and vertical

MATERIALS

Pump: Stainless steel

PRODUCT FEATURES

- Easy to install
- Trouble-free servicing
- Pressure transducer controlled
- Constant output
- Variable speed motors with consequently reduced noise
- Protection against dry running
- Accessories: hydro tube, connector, pressure gauge

APPLICATIONS

- Water supply
- Heating and air-conditioning
- Irrigation
- Water supply for heating and washing systems



For a complete list of technical information, consult www.lowara.com

Engineered for life



ITT

Lowara

General Catalogue

TKS SERIES OPERATING CHARACTERISTICS AT 50 Hz

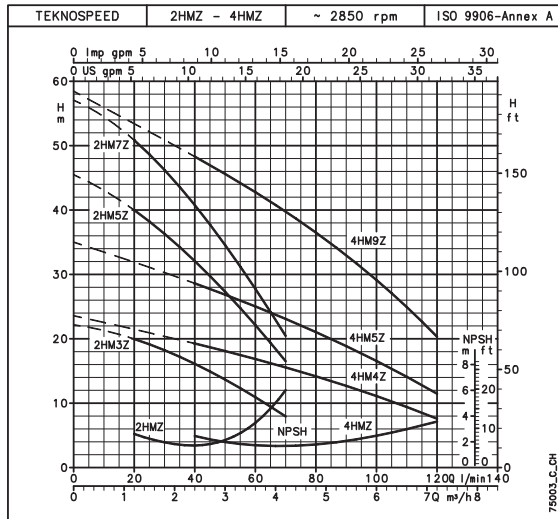

PUMP TYPE	RATED POWER		Q = DELIVERY												
	kW	HP	l/min	0	20	30	40	50	60	70	80	100	120	140	160
TKS/2HM3ZT	0,3	0,4	22,2	20,0	18,2	16,1	13,7	10,9	7,9						
TKS/2HM5ZT	0,55	0,75	45,5	40,0	36,3	32,1	27,3	22,1	16,5						
TKS/2HM7ZT	0,75	1	57,0	50,8	46,2	40,8	34,6	27,8	20,5						
TKS/4HM4ZT	0,45	0,6	23,6			19,3	18,1	16,9	15,6	14,2	11,1	7,6			
TKS/4HM5ZT	0,55	0,75	35,0			28,6	26,9	25,0	23,1	21,0	16,6	11,5			
TKS/4HM9ZT	1,1	1,5	58,4			48,3	45,6	42,8	39,8	36,5	29,1	20,3			

tk_s_hm-2p50_c_th

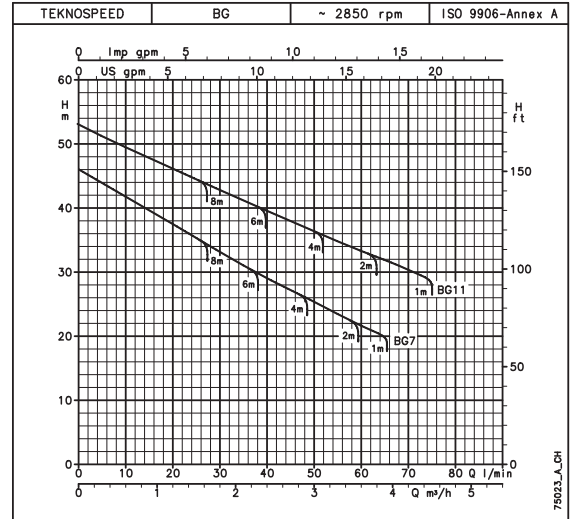

PUMP TYPE	RATED POWER		Q = DELIVERY												
	kW	HP	l/min	0	10	20	30	40	50	60	65	70			
TKS/BG7	0,75	1	45,4	0	0,6	1,2	1,8	2,4	3	3,6	4,2	4,8	6	7,2	
TKS/BG11	1,1	1,5	53,2	0	0,6	1,2	1,8	2,4	3	3,6	3,9	4,2	4,8	5,4	

tk_s_bg-2p50_a_th

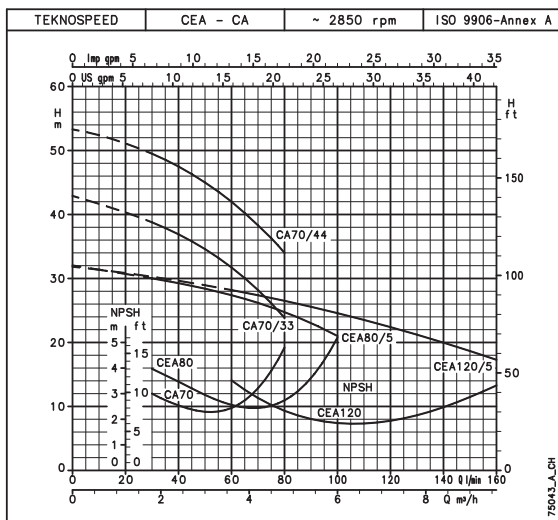

PUMP TYPE	RATED POWER		Q = DELIVERY												
	kW	HP	l/min	0	30	40	60	80	100	120	140	160			
TKS/CA 70/33	0,75	1	42,9	38,8	36,9	31,7	23,9								
TKS/CA 70/44	1,1	1,5	53,3	49,5	47,5	42,0	34,0								
TKS/CEA 80/5	0,75	1	32,0	30,0	29,3	27,4	24,7	21,0							
TKS/CEA 120/5	1,1	1,5	31,8			28,2	26,5	24,6	22,4	20,0	17,3				

tk_s_ca-cea-2p50_b_th

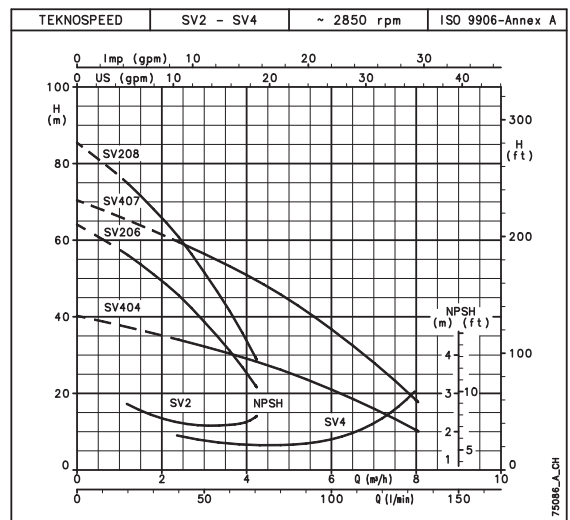

PUMP TYPE	RATED POWER		Q = DELIVERY												
	kW	HP	l/min	0	20	30	40	60	70	80	100	133			
TKS/SV206F07T	0,75	1	64,0	56,0	51,0	45,5	31,0	22,0							
TKS/SV208F11T	1,1	1,5	85,5	75,0	68,0	61,0	41,5	30,0							
TKS/SV404F07T	0,75	1	40,0			34,0	30,5	28,0	26,0	21,0	10,0				
TKS/SV407F11T	1,1	1,5	70,0			59,5	53,0	49,0	46,0	37,0	18,0				

tk_s_sv-2p50_a_th

Engineered for life



General Catalogue

TKS SERIES DIMENSIONS AND WEIGHTS

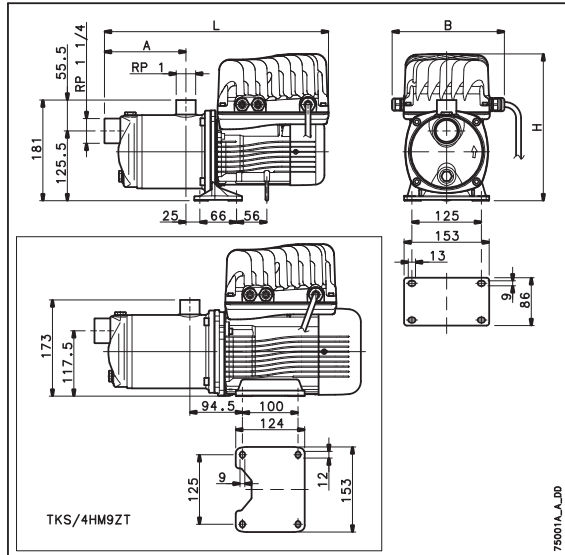

PUMP TYPE	N° STAGES	DIMENSIONS (mm)				WEIGHT kg
		H	L	B	A	
TKS / 2HM3ZT	2	264	354	202	96	9,6
TKS / 2HM5ZT	4	264	404	202	146	11,4
TKS / 2HM7ZT	5	274	435	202	171	14,2
TKS / 4HM4ZT	2	264	354	202	96	10,1
TKS / 4HM5ZT	3	264	379	202	121	10,9
TKS / 4HM9ZT	5	274	479	202	171	14,7

tk_s_hm-2p50_b_td

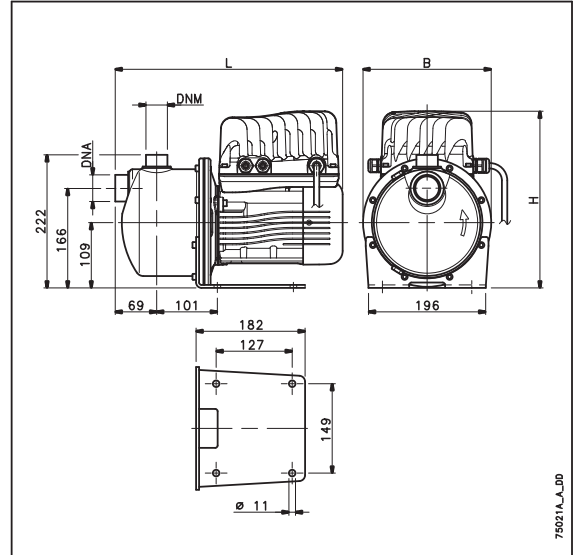

PUMP TYPE	DIMENSIONS (mm)					WEIGHT kg
	H	L	B	DNA	DNM	
TKS / BG7	295	380	215	Rp 1 1/4	Rp 1	15,5
TKS / BG11	303	425	215	Rp 1 1/4	Rp 1	18,5

tk_s_bg-2p50_a_td

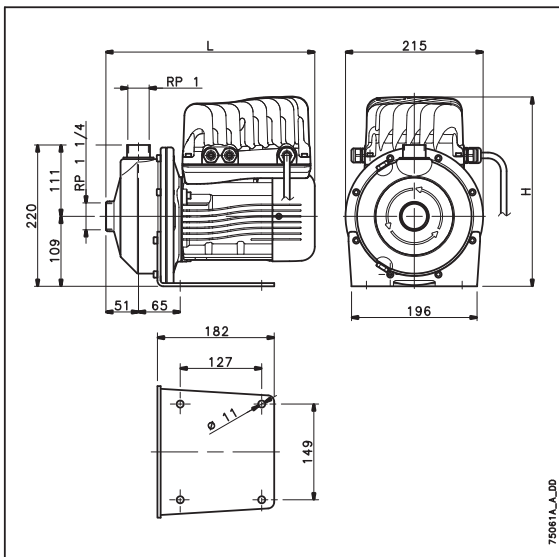

PUMP TYPE	DIMENSIONS (mm)		WEIGHT kg
	L	H	
TKS/CEA 80/5	325	295	15
TKS/CEA 120/5	370	303	15,5

tk_s_cea-2p50_a_td

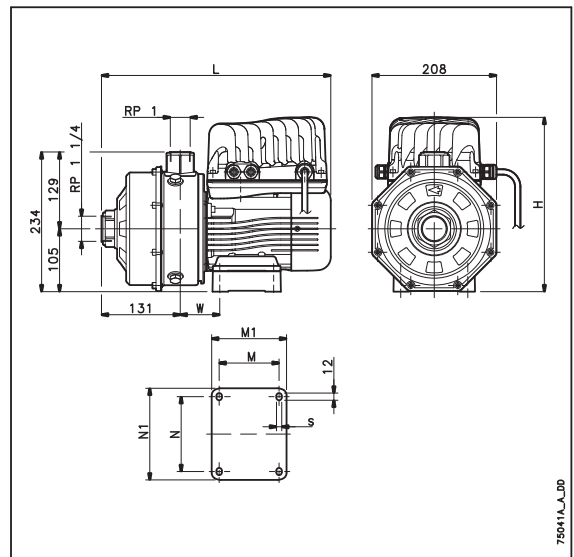

PUMP TYPE	DIMENSIONS (mm)								WEIGHT kg
	H	L	M	M1	N	N1	S	W	
TKS/CA 70/33	291	383	90	113	112	135	7	66	17,5
TKS/CA 70/44	299	420	100	125	125	153	9	76	21

tk_s_ca-2p50_a_td

Engineered for life



General Catalogue

TKS SERIES DIMENSIONS AND WEIGHTS

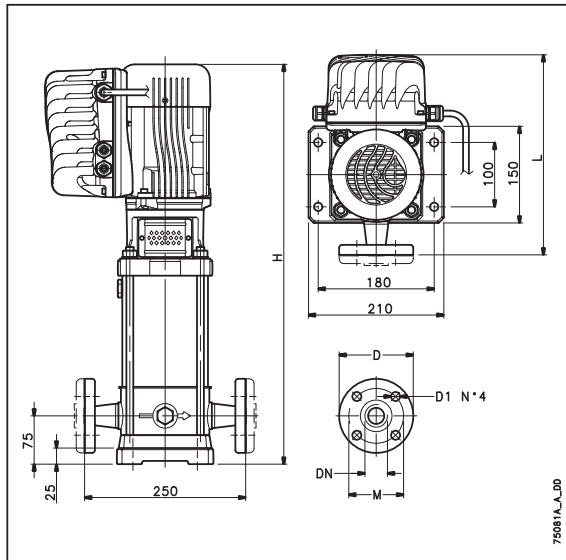

PUMP TYPE	DIMENSIONS (mm)						WEIGHT kg
	H	L	D	D1	M	DN	
TKS/SV206F07T	621	311	115	14	85	DN25 (Rp1)	24,5
TKS/SV208F11T	708	319	115	14	85	DN25 (Rp1)	25,5
TKS/SV404F07T	571	311	140	18	100	DN32(Rp1 1/4)	23,5
TKS/SV407F11T	683	319	140	18	100	DN32(Rp1 1/4)	25,5

tk_s_sv-2p50_a_td

UNIT TYPE*		Rated P [kW]	Input [A]	Q1 [l/min]	Q2 [l/min]	H1 [m]	H2 [m]
TKS/HMZ HORIZONTAL MULTI-STAGE WITH PLASTIC IMPELLERS							
	TKS/2HM3ZT	0.3	2.3	20	70	20.0	7.9
	TKS/2HM5ZT	0.55	3.5	20	70	40.0	16.5
	TKS/2HM7ZT	0.75	4.9	20	70	50.8	20.5
	TKS/4HM4ZT	0.45	3.0	40	120	19.3	7.6
	TKS/4HM5ZT	0.55	3.5	40	120	28.6	11.5
TKS/4HM9ZT	1.1	6.8	40	120	48.3	20.3	
TKS/BG SELF-PRIMING WITH AISI 304 STEEL IMPELLERS							
	TKS/BG7	0.75	4.9	20	60	38.1	25.6
	TKS/BG11	1.1	6.8	20	70	45.8	30.3
TKS/CA-CEA SINGLE/TWIN IMPELLERS IN AISI 304 STAINLESS STEEL							
	TKS/CEA80/5	0.75	4.9	30	100	30.0	21.0
	TKS/CEA120/5	1.1	6.8	60	160	28.2	17.3
	TKS/CA70/33	0.75	4.9	30	80	38.8	23.9
	TKS/CA70/44	1.1	6.8	30	80	49.5	34.0
TKS/SV VERTICAL MULTI-STAGE WITH AISI 304 STEEL IMPELLERS							
	TKS/SV206F07T	0.75	4.9	20	70	56.0	22.0
	TKS/SV208F11T	1.1	6.8	20	70	75.0	30.0
	TKS/SV404F07T	0.75	4.9	40	133	34.0	10.0
	TKS/SV407F11T	1.1	6.8	40	133	59.5	18.0

Engineered for life